

# ADC EcoDry ES-35

## 35-lb Capacity OPL Dryer

### Standard Features:

- 35-lb. Capacity
- Residual Moisture Control (RMC)
- Self-Diagnostic Microprocessor Control
- 100% Axial Airflow
- Completely Sealed Basket
- Non-Perforated Ribs and Basket
- Dual-Paned Door Glass
- Four-Point Roller Support System
- High Capacity Lint Drawer

### Optional Features:

- Stainless Steel Front, Cabinet & Basket
- Single Phase Reversing
- S.A.F.E. (Sensor Activated Fire Extinguishing System)



ES-35 OPL Dryer

### Why Purchase ADC EcoDry?

#### 100% Axial Airflow (standard)

EcoDry tumblers incorporate a 100% axial airflow design with a completely sealed basket. This ensures the most efficient drying available on the market today without sacrificing dry times.

#### Four-Point Roller Support System (standard)

EcoDryers are designed with a four-point roller support system, eliminating costly repairs and downtime due to trunnion failures.

#### Residual Moisture Control (standard)

EcoDry utilizes a unique Residual Moisture Control (RMC) sensing system to measure the presence of moisture in the load. The patented system senses when the load is dry, shutting the unit down to prevent over-drying. This saves time, utility costs as well as prolongs the life of dried items.

#### Available Option: Single Phase Reversing

Single Phase Reversing is an optional feature on the ES-35. What once was an expensive option requiring an upgrade from single phase to three phase electrical service is now available in single phase. A reversing tumbler ensures that the load doesn't "rope" or "ball up", providing a quicker, more even drying process.

Your local ADC independent authorized distributor



[www.amdry.com](http://www.amdry.com)

# ADC EcoDry ES-35

## ES-35 Specifications

Tumbler Capacity (dry weight)	35 lbs. (15.88 kg)																								
Tumbler Diameter	30" (76.20 cm)																								
Tumbler Depth	30" (76.20 cm)																								
Tumbler Volume	12.27 cu ft (347.44 L)																								
Tumbler/Drive Motor	1/4 hp (0.19 kW)																								
Blower/Fan Motor	1/2 hp (0.37 kW)																								
Door Opening (Diameter)	19-3/8" (49.21 cm)																								
Door Sill Height	37" (93.98 cm)																								
S.A.F.E. Water Connection	North America 3/4"-11.5 NH Outside North America 3/4" B.S.P.T.																								
Dryers per 20'/40' Container	14 / 28																								
Dryers per 53' Truck	36																								
Width	31.125" (79.06 cm)																								
Depth	40.424" (102.68 cm)																								
Height	67" (170.18 cm)																								
Airflow	60 Hz 319 cfm (9.03 cmm) 50 Hz 266 cfm (7.53 cmm)																								
Exhaust Connection	6" (15.24 cm)																								
GAS MODEL:	Approx. Net Wt. 462 lbs (209.6 kg) Approx. Ship Wt. 492 lbs (223.2 kg) Heat Input 60 Hz 64,000 btu/hr (16,128 kcal/hr) 50 Hz 55,000 btu/hr (13,860 kcal/hr) Inlet Pipe Connection 1/2" M.N.P.T. (CE and Australia Only) 3/8" M.B.S.P.T.																								
ELECTRICAL MODEL:	Approx. Net Wt. 462 lbs (209.6 kg) Approx. Ship Wt. 492 lbs (223.2 kg) Exhaust Connection (Diameter) 6" (15.24 cm)																								
<table border="1"> <thead> <tr> <th colspan="2">Oven Size per pocket</th> <th colspan="2">Oven Size per pocket</th> </tr> <tr> <th>kW</th> <th>Btu/hr (kcal/hr)</th> <th>kW</th> <th>Btu/hr (kcal/hr)</th> </tr> </thead> <tbody> <tr> <td>7.9</td> <td>26,962 (6,794)</td> <td>12.4</td> <td>42,320 (10,665)</td> </tr> <tr> <td>8.3</td> <td>28,327 (7,138)</td> <td>12.5</td> <td>42,661 (10,751)</td> </tr> <tr> <td>9.0</td> <td>30,716 (7,740)</td> <td>13.5</td> <td>46,074 (11,611)</td> </tr> <tr> <td>11.3</td> <td>38,566 (9,719)</td> <td></td> <td></td> </tr> </tbody> </table>		Oven Size per pocket		Oven Size per pocket		kW	Btu/hr (kcal/hr)	kW	Btu/hr (kcal/hr)	7.9	26,962 (6,794)	12.4	42,320 (10,665)	8.3	28,327 (7,138)	12.5	42,661 (10,751)	9.0	30,716 (7,740)	13.5	46,074 (11,611)	11.3	38,566 (9,719)		
Oven Size per pocket		Oven Size per pocket																							
kW	Btu/hr (kcal/hr)	kW	Btu/hr (kcal/hr)																						
7.9	26,962 (6,794)	12.4	42,320 (10,665)																						
8.3	28,327 (7,138)	12.5	42,661 (10,751)																						
9.0	30,716 (7,740)	13.5	46,074 (11,611)																						
11.3	38,566 (9,719)																								
STEAM MODEL:	Approx. Net Wt. 462 lbs (209.6 kg) Approx. Ship Wt. 492 lbs (223.2 kg) Steam Consumption 63 lb/hr (28.58 kg/hr) Operating Steam Pressure 150 psi max (10.34 bar) Exhaust Connection (Diameter) 6" (15.24 cm) Boiler Horsepower (Normal Load) 1.75 Bhp Supply Connection 1/2" F.N.P.T. Return Connection 1/2" M.N.P.T.																								

\* Specifications in parentheses are metric equivalents.

1/21/10

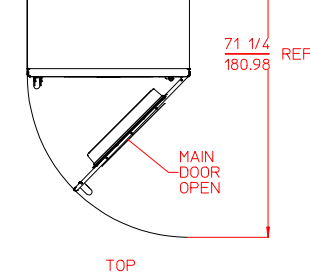
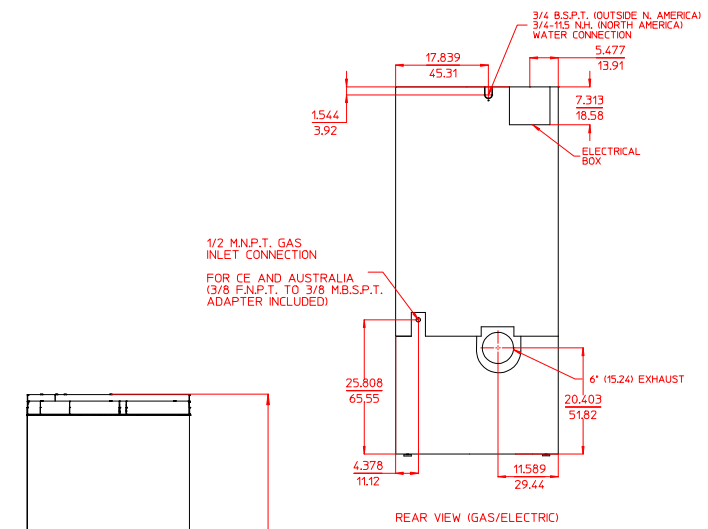
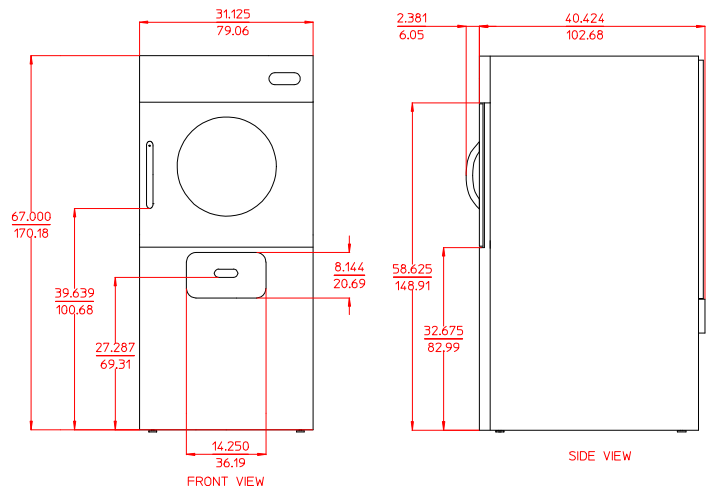

Electrical Service Specifications					
SERVICE VOLTAGE	PHASE	WIRE SERVICE	APPROX AMP DRAW		CIRCUIT BREAKER
			60 Hz	50 Hz	
<b>GAS</b>					
120	1ø	2	10.3	--	15
200	1ø	2	8.7	8.8	15
208	1ø	2	8.4	--	15
220	1ø	2	8.1	8.1	15
230	1ø	2	--	7.4	15
240	1ø	2	7.7	7.0	15
<b>STEAM</b>					
120	1ø	2	9.3	--	15
208	1ø	2	6.2	6.0	15
220	1ø	2	5.6	5.5	15
230	1ø	2	--	5.4	15
240	1ø	2	5.1	--	15

Electrical Service Specifications						
SERVICE VOLTAGE	PHASE	WIRE SERVICE	OVEN KW	APPROX AMP DRAW		CIRCUIT BREAKER
				60 Hz	50 Hz	
<b>ELECTRIC</b>						
200	1ø	2	12.5	68.4	67.7	90
208	1ø	2	7.9	43.8	--	60
208	1ø	2	13.5	70.7	--	90
220	1ø	2	7.5	36.9	--	40
230	1ø	2	8.3	--	41.3	60
230	1ø	2	12.4	--	59.1	80
240	1ø	2	9.0	42.7	--	60
240	1ø	2	13.5	61.5	--	80
208	3ø	3	13.5	43.3	--	60
220	3ø	3	11.3	35.3	--	50
230	3ø	3	12.4	--	36.5	50
240	3ø	3	13.5	37.7	--	50
380	3ø	4	11.3	22.8	22.6	40
400	3ø	4	12.4	--	23.1	40
416	3ø	4	13.5	--	23.7	40



88 Currant Road Fall River, MA 02720-4781 • 508.678.9000 • Fax: 508.678.9447 • Email: sales@amdry.com

P/N 450613.A 02/10

www.amdry.com